

# CR-4iA



Max. load capacity  
at wrist: **4 kg**



Max. reach:  
**550 mm**

Controlled axes	Repeatability (mm)	Mechanical weight (kg)	Motion range (°)						Maximum speed (°/s)						J4 Moment/ Inertia (Nm/kgm <sup>2</sup> )	J5 Moment/ Inertia (Nm/kgm <sup>2</sup> )	J6 Moment/ Inertia (Nm/kgm <sup>2</sup> )
			J1	J2	J3	J4	J5	J6	J1	J2	J3	J4	J5	J6			
6	± 0.01**	48	340	150	354	380	200	720	*1						8.86/0.2	8.86/0.2	4.9/0.067

## Working range

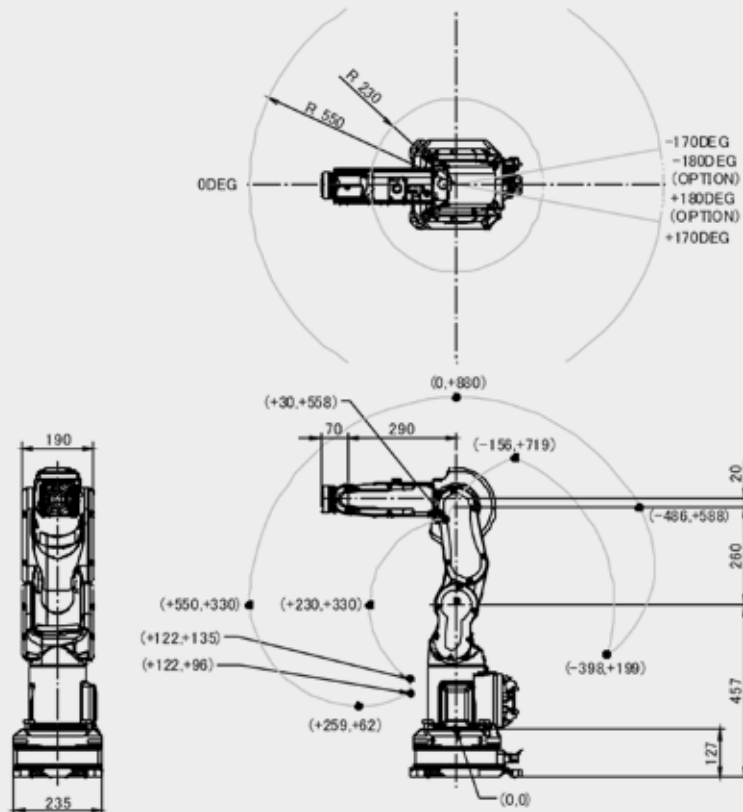

Motion range may be restricted according to the mounting angle!



### Robot

	CR-4iA
Robot footprint [mm]	296.5 x 235
Mounting position Floor	●
Mounting position Upside down	●
Mounting position Wall *2	●



### Controller

	R30iB
Open air cabinet	-
Mate cabinet	●
A-cabinet	-
B-cabinet	-
iPendant Touch	●

### Electrical connections

Voltage 50/60Hz 3phase [V]	-
Voltage 50/60Hz 1phase [V]	200-230
Average power consumption [kW]	0.5

### Integrated services

Integrated signals on upper arm In/Out	6/2
Integrated air supply	●

### Environment

Acoustic noise level [dB]	64.7
Ambient temperature [° C]	0-45

### Protection

Body standard/optional	IP67
Wrist & J3 arm standard/optional	IP67

\*1) max. cartesian speed 500mm/sec (1000mm/s when safety monitored)

\*2) In case of the wall mount, the operation space will be restricted according with the payload.

● standard ○ on request - not available ( ) with hardware and/or software option

\*\*Based on ISO9283